

*Royal Exclusiv pumps & skimmers*

Vorgebirgsstr. 28 // 50389 Wesseling // Germany

Fon +49(0)2236/88055-0 // Fax +49(0)2236/88055-20

info@royal-exclusiv.de // www.royal-exclusiv.de



## Data sheet STEP Dreambox® filter system

For a complete filter-system in free selectable Dimensions from 40 x 40 cm up to max. 80 x 60 cm

v1.0

**ENG**



## Data sheet STEP Dreambox® filter system

For a complete filter-system in free selectable Dimensions from 40 x 40 cm up to max. 80 x 60 cm

Filter-sock-system for the cleaning/filtration of Fresh- and Sea-water tanks. The STEP stands for variable, the customer can configure his desired measure in 2 cm steps.

The smallest STEP Dreambox® starts at a length of 40 cm and 40 cm depth up to a maximum of 80 x 60 cm. Between these two dimensions, the customer can adjust the box exactly to his needs, e.g. 60 x 54 cm or 78 x 56 cm, etc. ...

The box shown has a size 49 x 49 cm with a total height of 35 cm (including connections 40 cm and including cockpit 58 cm).

The STEP Dreamboxes are designed for customers with smaller tanks, but they still value RE-quality products and longevity, all in the smallest space.

The STEP Dreambox® is equipped with a pre-flood chamber and a filter sock, which can be freely selected at different mesh width depending on the application and trim.

The STEP Dreambox®-Filter provides crystal clear water, reduces phosphate and nitrate levels because the dirt is filtered out beforehand before decomposing by biological means. This relieves the burden on the system and creates for clear conditions in the reef aquarium. The integrated pre-flood chamber calms the inco-

ming water, the box has two connectors, 40 or 32 mm. The diameter of the screw-connection for the return pump is 25 mm. (For larger boxes also 32 mm possible at an additional cost)

Emphasis was putting on the ease of use of the box during the development. An integrated water level controller makes it easy to adjust the water level in the STEP Dreambox® from 16 up to 26 cm. All screws and water-touched metal parts are from titanium grade 2.

Even if the filter sock is blocked, the incoming water is passed on internally.

### Endowment include:

- PVC glass covers in 8 mm thickness
- The filter is made entirely of white PVC-U (hard) and is free of plasticizers, German quality product of Simona, approved for drinking water and TÜV monitored
- All turning and milling parts are all manufactured at RE on a state-of-the-art machinery
- Hand welded with red three-cantand welding wires
- Filter sock by default with 800µ
- Water level regulator

### Optional Available Accessories:

- RGB LED lighting with remote control
- Cartridges 80mm media filter, plinth glued to pedestal
- For example, matching 3000 liters DC delivery-pump for Media Filter and Bypass
- Matching RE skimmers e.g. Double Cone 130 with 12 volts DC skimmer pump
- return pump RD5 ECO with 4000 liters, 12 volts with TouchScreen
- Silicone tube coupling of the reproduction pump
- Built-in and glued pedestal for the Media filters
- Cable clamps
- Cover cutout for RE skimmers
- Internal piping including 1 x ball valve tap 20mm for bypass



## Data sheet STEP Dreambox® filter system

For a complete filter-system in free selectable Dimensions from 40 x 40 cm up to max. 80 x 60 cm

We would like to point out that we do not adapt third-party products or make lid cutouts for competitor skimmers.

If you want to use foreign products here, we will have closed lids delivered, which the customer can then adapt to his skimmer himself. Basically, closed and split 8mm PVC glass lids for the skimmers chamber are included in the basic equipment.

Due to the individual adjustment, the production delivery time is about 2-3 weeks after the order is received.

### Detailed product description:

Extra pockets are milled into the PVC side walls so that a sensor can be used to monitor the water level, so that the sensor is closer to the water, which reliably prevents false measurements. The sensor can be adjusted and locked with a sliding sled.

The STEP Dreamboxes basically have a pre-flood chamber, here the incoming water is first \*calmed\* and collected before it runs into the sock healing. The system has proven its worth in conventional sock recharger boxes. However, a \*cordoned off\* system is a prerequisite for the low-noise operation of the Dreambox®. Based on the previous media filters, with the proven subsurface flushing, the media filter 3.0 can be screwed up as a kind of cartridge system on a flange tightly bonded in the floor (pedestal).

The piping and pump, as well as the flange remain in the filter, the medium is removed from the Dreambox® in the cartridge.

The media filter is no longer regulated with a ball valve tap, but for example with a Red Dragon® X with 30 watts. This makes it easy to adjust the flow without resistance. To unscrew the cartridge, no plug has to be pulled, but the pump is stopped via the controller.

The media filter has a diameter of 80 mm and is custom-made, especially for the STEP Dreamboxes.



## Royal Exclusiv pumps & skimmers

Vorgebirgsstr. 28 // 50389 Wesseling // Germany

Fon +49(0)2236/88055-0 // Fax +49(0)2236/88055-20  
info@royal-exclusiv.de // www.royal-exclusiv.de



Individual adaptation to your desired dimensions  
From 400 mm x 400 mm  
until  
Maximum 800 mm x 600 mm

All dimensions possible in 20 mm steps possible in this area:  
E.g. 420 x 580 mm, 540 x 600 mm,  
720 x 680 mm ...

Simply non-binding offer request at  
info@royal-exclusiv.de



*Royal Exclusiv pumps & skimmers*

Vorgebirgsstr. 28 // 50389 Wesseling // Germany

Fon +49(0)2236/88055-0 // Fax +49(0)2236/88055-20  
info@royal-exclusiv.de // www.royal-exclusiv.de



# Royal Exclusiv pumps & skimmers

Vorgebirgsstr. 28 // 50389 Wesseling // Germany

Fon +49(0)2236/88055-0 // Fax +49(0)2236/88055-20  
info@royal-exclusiv.de // www.royal-exclusiv.de



Since 1986

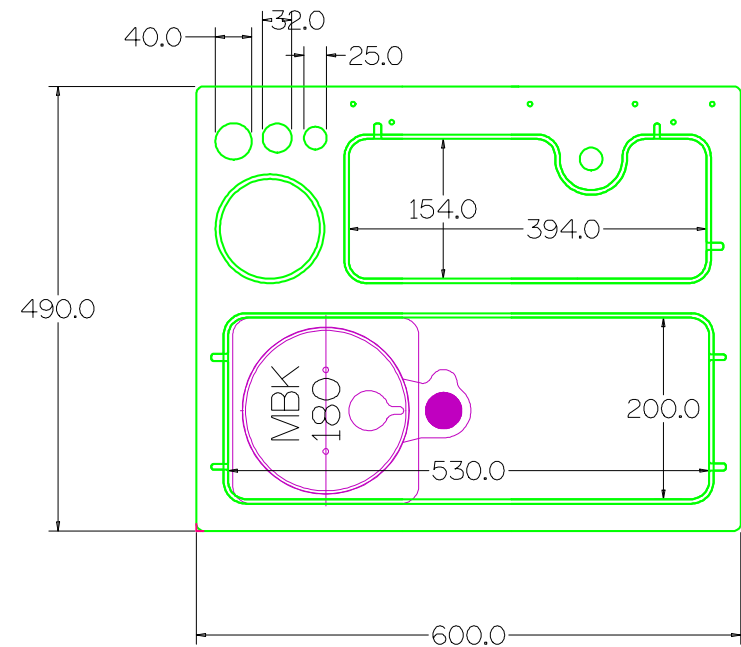
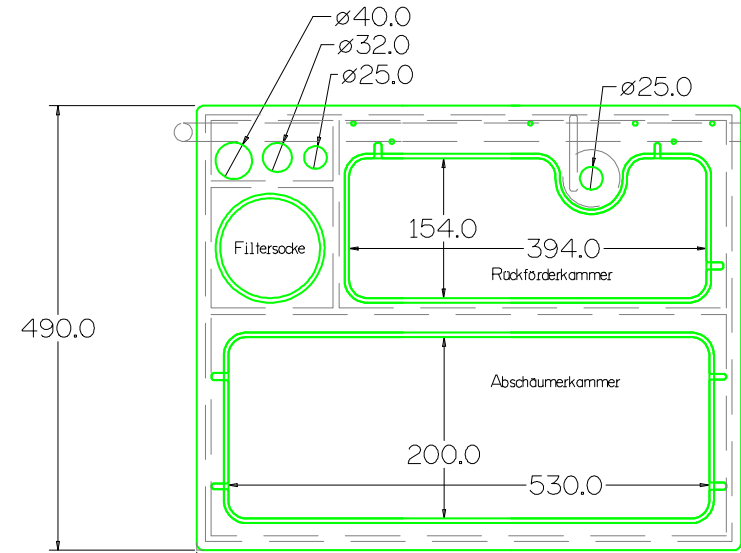
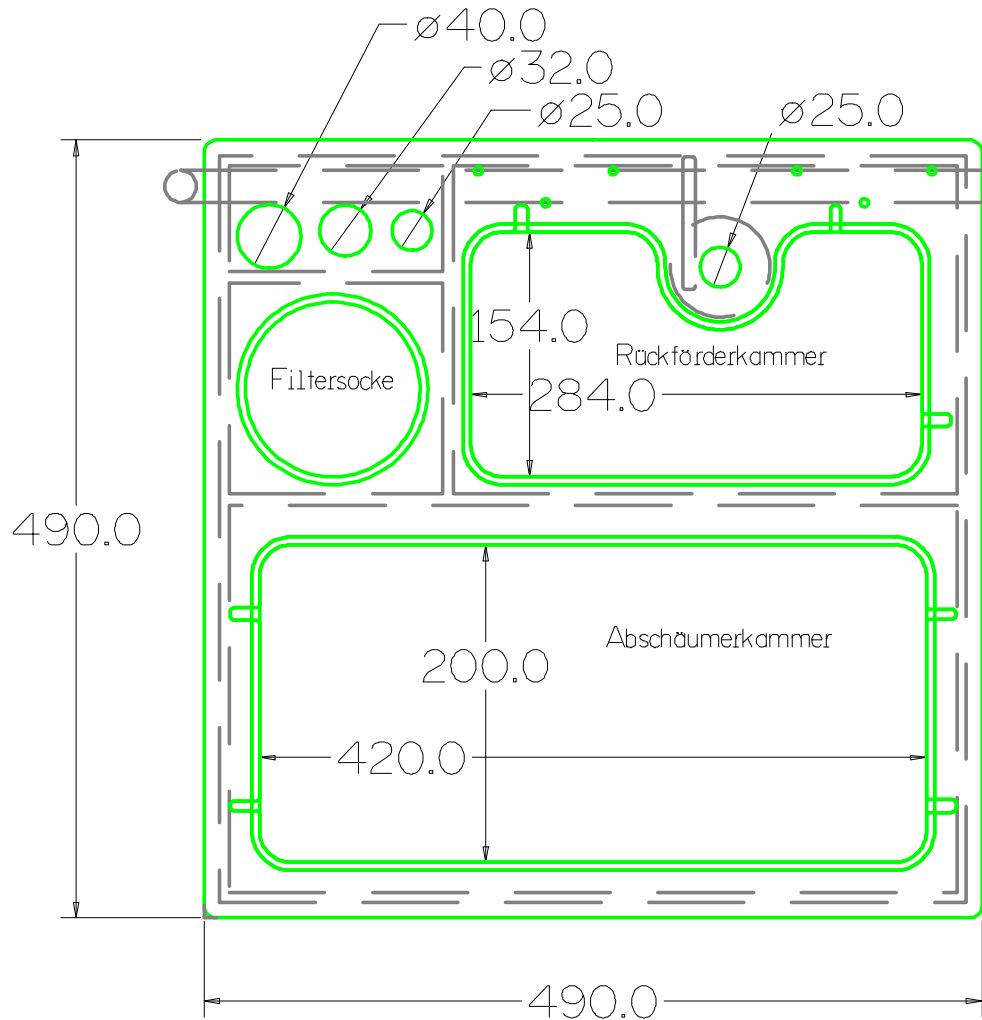

# Royal Exclusiv pumps & skimmers

Vorgebirgsstr. 28 // 50389 Wesseling // Germany

Fon +49(0)2236/88055-0 // Fax +49(0)2236/88055-20  
info@royal-exclusiv.de // www.royal-exclusiv.de

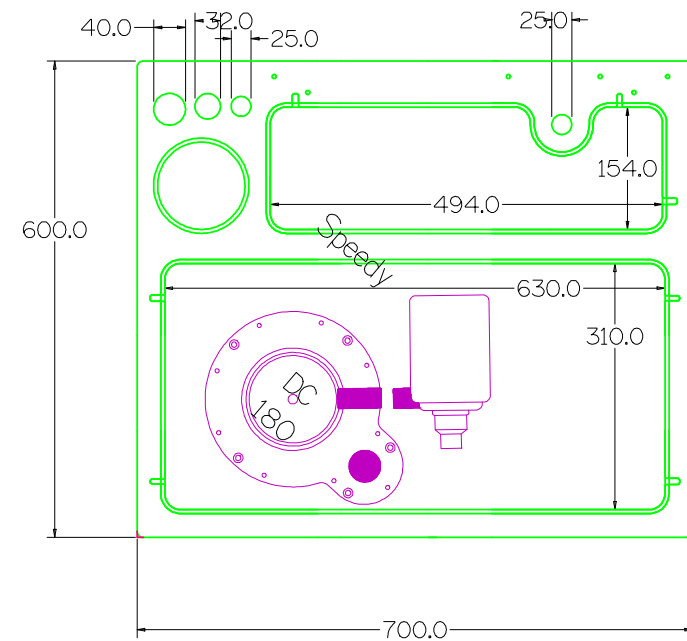
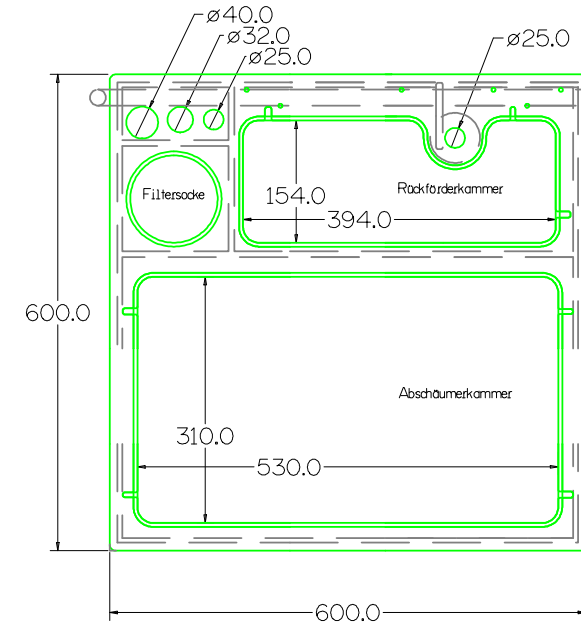
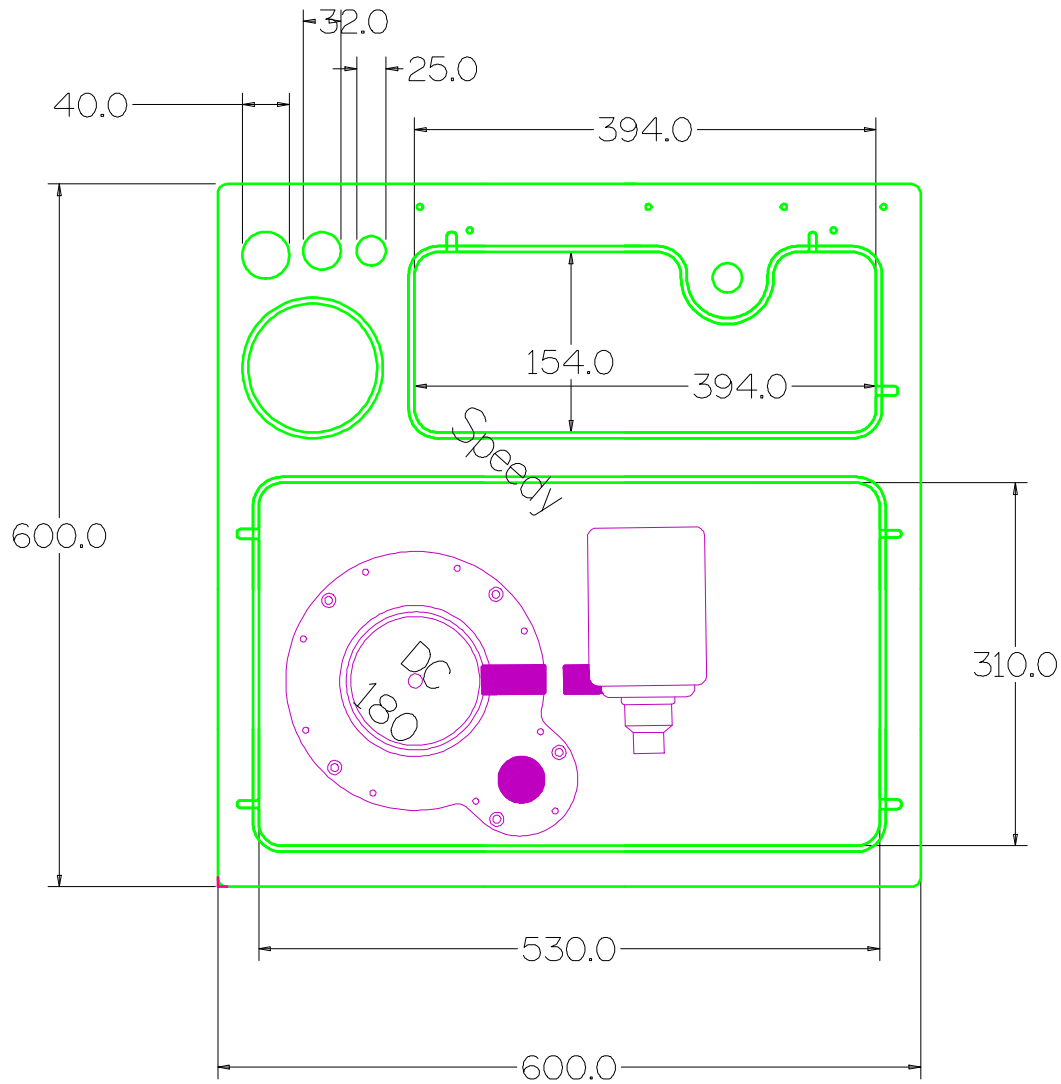

*Royal Exclusiv pumps & skimmers*

Vorgebirgsstr. 28 // 50389 Wesseling // Germany

Fon +49(0)2236/88055-0 // Fax +49(0)2236/88055-20  
info@royal-exclusiv.de // www.royal-exclusiv.de



*Since 1986*





*Royal Exclusiv pumps & skimmers*

Vorgebirgsstr. 28 // 50389 Wesseling // Germany

Fon +49(0)2236/88055-0 // Fax +49(0)2236/88055-20  
info@royal-exclusiv.de // www.royal-exclusiv.de



*Since 1986*



*Royal Exclusiv pumps & skimmers*

Vorgebirgsstr. 28 // 50389 Wesseling // Germany

Fon +49(0)2236/88055-0 // Fax +49(0)2236/88055-20  
info@royal-exclusiv.de // www.royal-exclusiv.de



*Since 1986*

