

Royal Exclusio pumps & skimmers

Vorgebirgsstr. 28 // 50389 Wesseling // Germany

Fon +49(0)2236/88055-0 // Fax +49(0)2236/88055-20

info@royal-exclusiv.de // www.royal-exclusiv.de



Since 1986



Operating and maintenance instructions for float switch

For all switchable electric outlets with Dreambox - special - float switches

v2.0

ENG



Operating and maintenance instructions for float switch

For all switchable electric outlets with Dreambox - special - float switches

1. Foreword

The float switch with switchable power outlet can be used as level switch in water tanks, filter tanks, or refugia, etc.. The switch is factory equipped with a normally-open contact, which shuts the power outlet with power in case of activation.

2. Commissioning and switching angle

Please see the switchable electric outlet with the float switch from the packaging and check the product for any shipping damage must appear immediately within 24 hours, at the competent dealer.

The switchable electric outlet with float switch is fully pre-installed and can immediately in a filter sump, etc. to be installed. !! Maximum load: **500 Watts!!** or **max. 3A!**

The float switch is fixed by the connection to the red plastic tube, which is so firmly attached to the Dreambox. The float switch follows the level. The built-in contact switches when approximately 5-15 ° under or above the freezing point.

3. Maintenance

The operation of the device is maintenance-free. For proper functioning, it is worth noting:

The active surface and if necessary a freedom from deposits and foreign bodies are free to keep.

Attention!

**Maximum switchable performance
500 Watts!!**



Important Notice

Please read this manual carefully before you install the device. We recommend not to proceed the installation of the device until you read the manual. This prevents any questions and problems that might occur in installation process. As soon as you power-on the device for the first time, you agree that you read and understood this manual. In doubt or if anything is unclear please contact your supplier/vendor or dealer before you start-up the device.

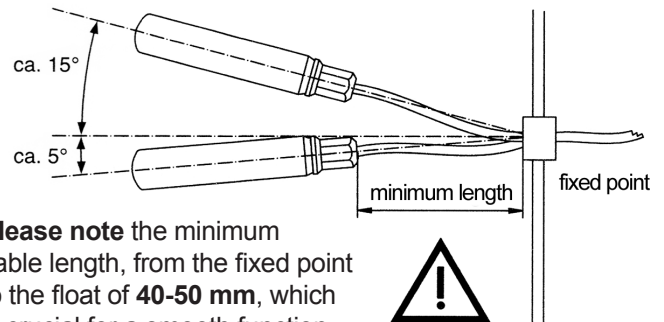

Please note the minimum cable length, from the fixed point to the float of **40-50 mm**, which is crucial for a smooth function.

4. Technical data

Operating temperature:	+0° ... +60°
maximum immersion depth:	5m
Control voltage:	4V - 250V AC 4V - 30V DC
Switching current::	1mA - 3A
Switching element:	micro switch potential-free changeover contact

Contacts:	—○ NO
NO C NC	—○ C
brown black blue	—○ NC

5. Security advisories

- Note maximum load, relay insert with larger loads
- Connect the device only to the control voltage specified in the technical data
- Do not open the cable gland
- Socket and Terminal contacts can be rewired as needed. (Only by electric expert)
- For Assembly and maintenance work, the float switch is voltage free switch

Please note:

The exact switching point is determined by the length of the cable between the fixing point and swimmer sleeve and of the rate of change of level.



6. Defects and claims for compensation, disclaimer

6. Defects and claims for compensation

6.1. Barring any further claims we are only liable that the supplied goods are free of defects until the initial transfer of perils. Insignificant variations of the contracted appearance and workmanship or marginal limitation of the usability or suitability of the product are unremarkable.

The warranted condition, endurance and usability the product is solely subject to the specification agreed in writing, in the product specification and / or in this manual. Further oral agreements, especially from preliminary talks, advertising and / or in related industrial standards will be only valid as integral part of a written contract. Only conditions and specifications assured specifically by us are valid. We do not accept conditions or specifications made by third parties. Specifically the specification assured in this manual are valid. If the customer wants to use the product for other than the intended purpose, he is obliged to thoroughly check the suitability of the product for the other purposes. We give no warranty and no liability accrues for any applications that are not agreed on by us explicitly and in written form.

Any manipulation of the device the electronic as well as any attempt to modify the software, to influence the software or to read out or re-engineer the software of the driver unit immediately causes a loss of warranty and all claims and rights expire.

Every user is held responsible for the appropriate usage of his **switchable electric outlets with Dreambox - special - float switches**. The user manual does not discharge you from your liability for a safe, appropriate and secure application, installation, operation and maintenance.

By using this manual you agree that in no circumstances the manufacturer can or will be held liable for any personal injuries or property damages which possibly occur due to the usage of the device. This applies specifically for any damages that are due to inappropriate piping or plumbing. Insufficient or missing cleaning- or maintenance intervals and damages that might result due to these are not covered by warranty. This applies especially for calcinations (salt water usage) and accumulated foreign particles (pond usage) such as sand or gravel, which lead to damages on rotors, bearings, rotor housing or motor housing, that are not covered by warranty.

6.2. Our warranty for defects is strictly limited to supplementary performance. This is upon our choice either removal of defects or replacement delivery free from defects. In the case of challenge, impossibility or failure of the supplementary performance the customer has the right for impairment or the right to withdraw from the contract.

Additional expenses which arise because the customer has brought the sales item to another place than his subsidiary. The manufacturer explicitly limits the warranty to the device itself. We are not liable for consequential damages, or damages that are caused by a malfunction or failure of the device, such as a loss of animals. It is in the responsibility of the customer to provide back-up devices for the case of a potential malfunction or failure of the device.

6.3. The customer has to check the goods immediately thoroughly, also for product safety. Apparent damages have to be reported in written form immediately. Hidden damages have to be reported immediately after their discovery. The customer is liable to report transport damages within 24 hours to the carrier and/or the delivery service. Disregarding the rules for checking and reporting results in a loss of warranty.

6.4. Furthermore we are not liable for the consequences of inappropriate application, usage, maintenance and handling of the product by the customer or his subsidiaries, neither for normal abrasion. This applies specifically to the consequences of thermal, chemical, electrochemical or electrical influences as well as for infringements against our uses- and maintenance manuals. The same applies to damages which are the result of changes or adjustments by the customer which have not been approved by us in beforehand.

6.5. Our liability for wanton negligence is limited to claims of injury of life, body and health, to claims based upon the law on product liability and to claims from culpable fundamental breach of the contract which peril contractual obligations. For the rest our liabilities for wantonly negligent breach of contractual obligations, which are foreseeable at the time of the conclusion of the contract, are barred.

Damages, which are unambiguously attributed to inappropriate usage of the product, are in general to be accounted for by the customer. In the case of returns of the product the customer has to use break-proof packaging for the product. The customer is liable for any damages that can be accounted to an inappropriate packaging.

6.6. Claims against us become time-barred within a year after the initial delivery of the goods to the customer. The same applies to claims for damages regardless of their juridical cause. The limitation period does not apply to claims based upon the malicious concealment of damages from the injury of life, health or body and for other damages that result out of intention or wanton negligence.

6.7. If it becomes apparent during our examination of damages reported by the customer or in the course of our removal of defects, that the reported damages or claims were made wantonly negligent or unwarranted, we may charge an adequate consideration for our examination and for the removal of defects. The customer has the right to neglect a necessary repairing and to demand the return of the device. In general every examination of damages is bound to lump-sum compensation if it occurs that the customer has to be accounted for the damages.

6.8. Spare parts

Our liability to deliver and hold spare parts available is limited to the period of 5 years after initial shipment of the product. Our respective list prices apply for spare parts.

6.9. Disposal

We offer our customers to take back products that fall under the restriction of hazardous substances directive (ElektroG) within Germany free of charge, for products, which were brought into circulation after the 13th of August 2005. We will take care for the disposal. If a customer chooses not to let us take care for the disposal, he takes the responsibility of a disposal according to legal regulations and discharges us from our liabilities according to §10 sect. 2 ElektroG and any associated liabilities of others.

6.10. Subject to alterations

The manufacture has the right for changes in hardware and software of the product at any time without preliminary notice, as long as these changes advance reliability or quality of the device. No claims can be made if for instance design, functionality or performance of the device changes elementary. The assured specification of the device is always guaranteed.

7. Manufacturer's declaration

Titles against **Royal Exclusiv®** concerning the products described in this manual adress on the **Royal Exclusiv®** guarantee clauses. Specification may vary due technical improvements.

7.1. Manufacturer

Royal Exclusiv® pumps and skimmers

Vorgebirgsstr. 28 // 50389 Wesseling // Germany

Fon +49(0)2236/88055-0 // Fax +49(0)2236/88055-20

info@royal-exclusiv.de // www.royal-exclusiv.de

Made in Germany

Royal-Exclusiv® EAR-number: WEE.Reg.No. 83082352

7.2. Informations and support

Thank your for purchasing a **Royal Exclusiv®** float switch. This device is a high quality product made in Germany with the highest manufacturing demands on modern CNC machines. This manual is supposed to help you to setup the float switch for use and to advice you with the necessarily maintenance procedures.

To ensure longlasting satisfaction with this product we please you to read this manual carefully and follow our guidelines.

Royal Exclusiv® guarantees 5 years of spare part availability for the float switch.

Should the device in some way not meet the high demands you expect from **Royal Exclusiv®** please contact the dealer where you purchases your float switch. This is usually the best way for product support. However you may feel free to contact our support on our website: <http://www.royal-exclusiv.de>

